

- Type:** Single Point
- Material:** Stainless Steel
- Protection:** IP 68
- Features:** Suggested Platform Size: 400x400 mm
- Application:** Bench Scales  
Multi Head Weighers  
Check Weighers

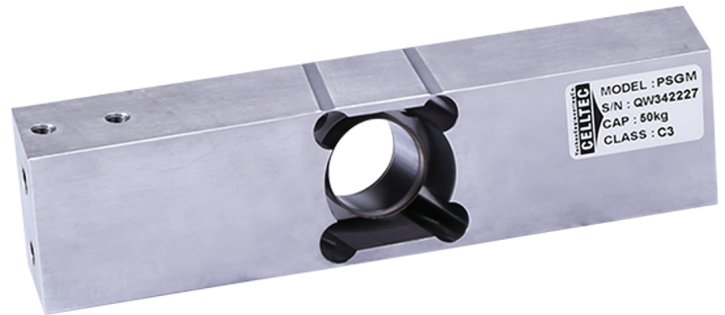

### Specifications:

Capacity		10kg / 20kg / 50kg / 75kg / 100kg	
Accuracy Class		C3	C4
Max. Number of Verification Intervals	$n_{max}$	3000	4000
Minimum Load Cell Verification Level	$v_{min}$	$E_{max}/10000$	$E_{max}/12000$
Temperature Effect on Zero	%FS/10°C	$\leq \pm 0.0165$	$\leq \pm 0.0090$
Temperature Effect in Sensitivity	%FS/10°C	$\leq \pm 0.0137$	$\leq \pm 0.0110$
Combined Error	%FS	$\leq \pm 0.0200$	$\leq \pm 0.0140$
Creep	%FS	$\leq \pm 0.0165$	$\leq \pm 0.0148$
Output Sensitivity	mv/v	$2.0 \pm 0.2$	
Input Resistance	$\Omega$	$380 \pm 10$	
Output Resistance	$\Omega$	$350 \pm 3.5$	
Insulation Resistance	M $\Omega$	$\geq 5000$	
Zero Balance	%FS	$\leq 1.5$	
Temperature, Compensated	°C	-10 ~ +40	
Temperature, Operating	°C	-30 ~ +70	
Excitation, Recommended	v	5 ~ 12	
Safe Overload	%FS	150	
Ultimate Overload	%FS	300	
Standard Cable length	m	3.0	

### Dimensions:

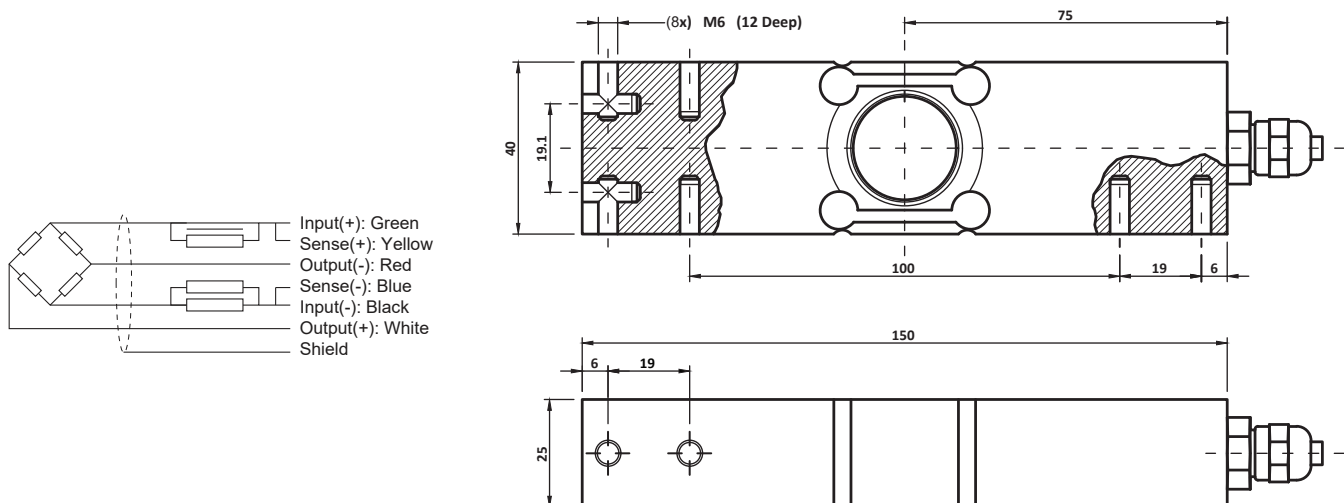

All dimensions: mm.