

- Type:** Single Point
- Material:** Aluminum Alloy
- Surface:** Anodized Treatment
- Protection:** IP 65
- Features:** Suggested Platform  
Size: 200 x 200 mm
- Application:** Bench & Counting Scales  
Bagging Machine  
Check Weigher



### Specifications:

Capacity		0.3kg / 0.4kg / 0.5kg / 0.6kg / 1kg / 3kg
Accuracy Class		<b>C3</b>
Max. Number of Verification Intervals	$n_{max}$	3000
Minimum Load Cell Verification Level	$v_{min}$	$E_{max}/7000$
Temperature Effect on Zero	%FS/10°C	$\leq \pm 0.0200$
Temperature Effect in Sensitivity	%FS/10°C	$\leq \pm 0.0175$
Combined Error	%FS	$\leq \pm 0.0250$
Creep	%FS	$\leq \pm 0.0167$
Output Sensitivity	mv/v	$1.0 \pm 0.1$
Input Resistance	$\Omega$	$395 \pm 5$
Output Resistance	$\Omega$	$350 \pm 3.5$
Insulation Resistance	M $\Omega$	$\geq 5000$
Zero Balance	%FS	$\leq 2.0$
Temperature, Compensated	°C	-10 ~ +40
Temperature, Operating	°C	-20 ~ +50
Excitation, Recommended	v	5 ~ 15
Safe Overload	%FS	150
Ultimate Overload	%FS	300
Standard Cable length	m	0.45

### Dimensions:

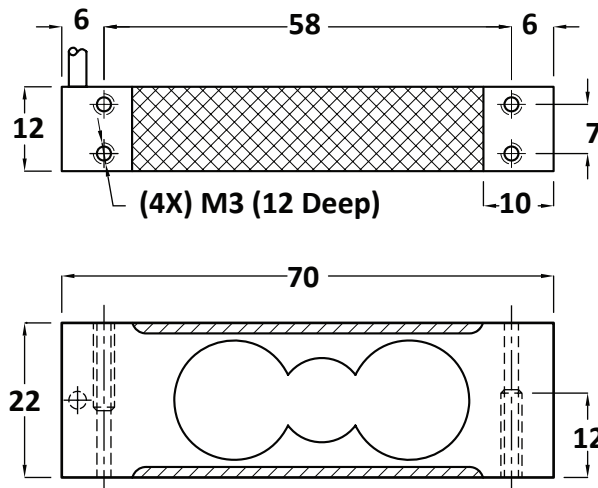
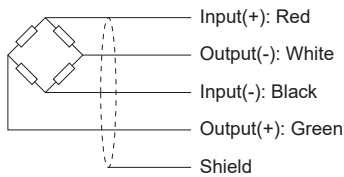

All dimensions: mm.